

2726CH1

Nickel-Cadmium Aircraft Battery

Ultra Low Maintenance



Saft are leaders in providing completely reliable low maintenance, low life-cost Ni-Cd batteries for commercial, business and military aircraft operation, with guaranteed service. Designed, solidly built and optimized for your application, Saft aviation batteries deliver high power in extreme temperatures, withstand punishing electrical and physical abuses, and at least halve annual maintenance events.



Key features

- Superior power and energy
- Extended battery service life
- Unmatched reliability
- Leak-proof thermo-welded cells
- Seam-welded plate tabs copper cell links and terminals
- Superior separator material
- Flooded membrane design

Applications

Fixed wing aircraft

Embraer 170/190 Series

Electrical characteristics

Nominal voltage	22.8 volts
Nominal capacity	27 Ah at 1 hour rate
Recommended constant charging voltage	27 volts

Dimensions

Length	276 mm / 10.9 in
Width	236 mm / 9.3 in
Height	226 mm / 8.9 in
Weight	24.6 kg / 54.3 lbs

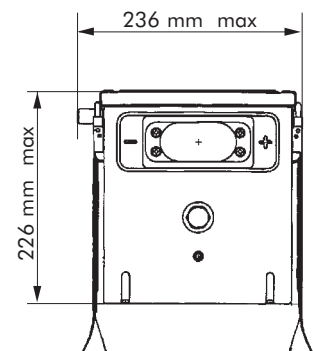
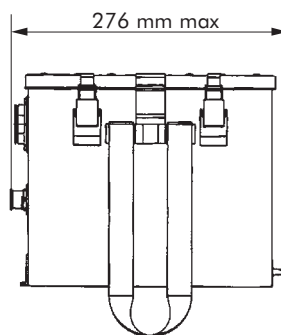

Saft

12, rue Sadi Carnot
93170 Bagnole - France
Tel: +33 (0)1 49 93 19 18
Fax: +33 (0)1 49 93 19 56

Saft America, Inc.

711, Industrial Blvd
Valdosta
Georgia, 31601 - USA
Tel: +1 (229) 247 2331
Fax: +1 (229) 247 8486

www.saftbatteries.com

Doc. n° 22046-2-0404
Data in this document are subject to change without notice and become contractual only after written confirmation by Saft.

April 2004



saft