

# DC 2408NL SERIES FAN



## FEATURES:

- Size 2.36 in sq. X 0.79 in (60mm sq. X 20mm)
- Airflow 11-18 CFM
- Weight 2.1 oz (60g)
- Noise 22-31 dBA
- Lead Wire AWG 24, Red/Black, UL1007, CSA TR-64

- Impeller and Venturi UL94V-0 Reinforced plastic

- † Non-stock item, may be subject to lead time
- †† Rib-type is a non-stock item, may be subject to lead time

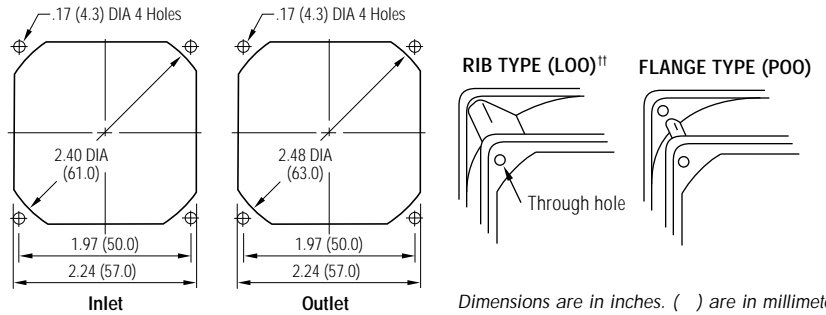
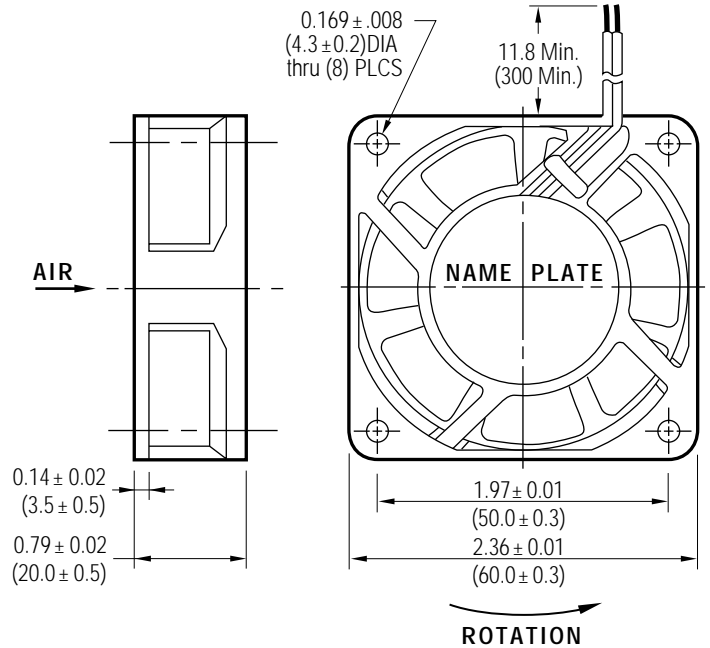

Dimensions are in inches. ( ) are in millimeters

| MODEL              | VOLTAGE (V) | RANGE (V) | POWER (W) | CURRENT (mA) | SPEED (RPM) | NOISE (dBA) | NOISE NIPEL (BELS) |      |      |      | PRESSURE (in H <sub>2</sub> O) | AIRFLOW CFM | MODEL              | VOLTAGE (V) | RANGE (V) | POWER (W) | CURRENT (mA) | SPEED (RPM) | NOISE (dBA) | NOISE NIPEL (BELS) |      |      |      | PRESSURE (in H <sub>2</sub> O) | AIRFLOW CFM |
|--------------------|-------------|-----------|-----------|--------------|-------------|-------------|--------------------|------|------|------|--------------------------------|-------------|--------------------|-------------|-----------|-----------|--------------|-------------|-------------|--------------------|------|------|------|--------------------------------|-------------|
|                    |             |           |           |              |             |             | 100%               | 80%  | 60%  | 20%  |                                |             |                    |             |           |           |              |             |             | 100%               | 80%  | 60%  | 20%  |                                |             |
| 2408NL-04W-B10-POO | 12          | 6-13.8    | 0.60      | 50           | 2800        | 22          | 4.10               | 4.20 | 4.14 | 4.19 | 0.07                           | 11          | 2408NL-05W-B10-POO | 24          | 15-27.6   | 0.96      | 40           | 2800        | 22          | 4.10               | 4.20 | 4.14 | 4.19 | 0.07                           | 11          |
| B20-POO†           | 12          | 6-13.8    | 0.84      | 70           | 3200        | 25          | 4.20               | 4.17 | 4.44 | 4.43 | 0.09                           | 13          | B20-POO†           | 24          | 15-27.6   | 0.96      | 40           | 3200        | 25          | 4.20               | 4.17 | 4.44 | 4.43 | 0.09                           | 13          |
| B30-POO            | 12          | 6-13.8    | 0.96      | 80           | 3600        | 27          | 4.39               | 4.52 | 4.76 | 4.69 | 0.12                           | 15          | B30-POO            | 24          | 15-27.6   | 1.08      | 45           | 3600        | 27          | 4.39               | 4.52 | 4.76 | 4.69 | 0.12                           | 15          |
| B40-POO†           | 12          | 6-13.8    | 1.08      | 90           | 4000        | 29          | 4.73               | 4.98 | 5.06 | 4.92 | 0.13                           | 16          | B40-POO†           | 24          | 15-27.6   | 1.20      | 50           | 4000        | 29          | 4.73               | 4.98 | 5.06 | 4.92 | 0.13                           | 16          |
| B50-POO            | 12          | 6-13.8    | 1.32      | 110          | 4400        | 31          | 5.27               | 5.05 | 5.28 | 5.29 | 0.17                           | 18          | B50-POO            | 24          | 15-27.6   | 1.32      | 55           | 4400        | 31          | 5.27               | 5.05 | 5.28 | 5.29 | 0.17                           | 18          |

