

# DC 3110KL SERIES FAN

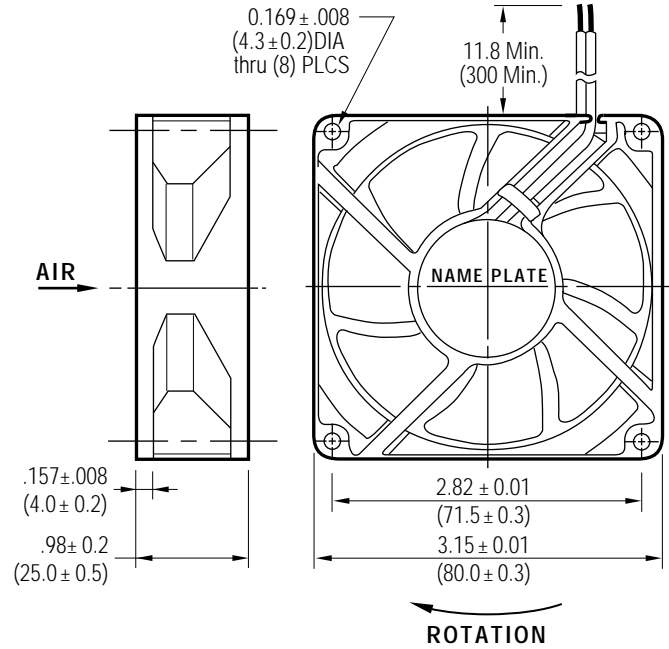

## FEATURES:

- Size 3.15 in sq. X 0.98 in (80mm X 25mm)
- Airflow 25 - 40 CFM
- Weight 3.3 oz (93g)
- Noise 22 - 35 dBA
- Lead Wire AWG 24, Red/Black, UL1007, CSA TR-64

Impeller and Venturi UL94V-0 Reinforced plastic

- † Non-stock item, may be subject to lead time
- †† Rib-type is a non-stock item, may be subject to lead time

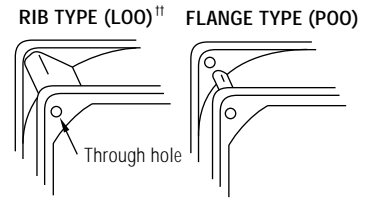
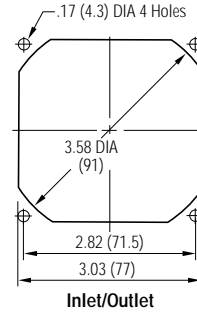

Dimensions are in inches. ( ) are in millimeters

MODEL	VOLTAGE (V)	RANGE (V)	POWER (W)	CURRENT (mA)	SPEED (RPM)	NOISE (dBA)	NOISE NPEL (BELS)				PRESSURE (in H <sub>2</sub> O)	AIRFLOW (CFM)	MODEL	VOLTAGE (V)	RANGE (V)	POWER (W)	CURRENT (mA)	SPEED (RPM)	NOISE (dBA)	NOISE NPEL (BELS)				PRESSURE (in H <sub>2</sub> O)	AIRFLOW (CFM)
							100%	80%	60%	20%										100%	80%	60%	20%		
3110KL-04W-B10-P00	12	6 - 13.8	1.20	100	2150	22	4.25	4.17	4.01	4.19	0.06	25	3110KL-05W-B10-P00	24	10 - 27.6	1.44	60	2150	22	4.25	4.17	4.01	4.19	0.06	25
B20-P00†	12	6 - 13.8	1.32	110	2400	25	4.45	4.31	4.31	4.43	0.08	28	B20-P00†	24	10 - 27.6	1.68	70	2400	25	4.45	4.31	4.31	4.43	0.08	28
B30-P00	12	6 - 13.8	2.04	170	2700	28	4.98	4.78	4.81	4.73	0.10	32	B30-P00	24	10 - 27.6	1.92	80	2700	28	4.98	4.78	4.81	4.73	0.10	32
B40-P00†	12	6 - 13.8	2.40	200	3000	31	4.91	4.84	4.72	4.96	0.13	35	B40-P00†	24	10 - 27.6	2.40	100	3000	31	4.91	4.84	4.72	4.96	0.13	35
B50-P00	12	6 - 13.8	2.76	230	3250	34	5.23	5.01	5.10	5.35	0.15	39	B50-P00	24	10 - 27.6	2.88	120	3250	34	5.23	5.01	5.10	5.35	0.15	39
B60-P00†	12	6 - 13.0	3.12	260	3400	35	N/A	N/A	N/A	N/A	0.16	42	B60-P00†	24	10 - 26.4	3.36	140	3400	35	N/A	N/A	N/A	N/A	0.16	40

