

Preliminary

Ver.: 0.10

TFT LCD Specification

Model Name: TD070WGCB2

Customer Signature
Date

This technical specification is subjected to change without notice.

The information contained herein is the exclusive property of toppoly Optoelectronics corporation, and shall not be distributed, reproduced, or disclosed in whole or in part without prior written permission of toppoly Optoelectronics corporation.

Table of Contents

NO.	Item	Page
	Cover Sheet	1
	Table of Contents	2
	Record of Revision	3
1	Features	4
2	General Specifications	4
3	Input / Output Terminals	5
4	Absolute Maximum Ratings	7
5	Electrical Characteristics	7
6	Timing Chart	8
7	Optical Characteristics	10
8	Reliability	13
9	Handling Cautions	14
10	Mechanical Drawing	15
11	Packing Drawing	16

1. FEATURES

The 7.0"(17.8 cm) LCD module is an active matrix color TFT LCD module. LTPS (Low Temperature Poly Silicon) TFT technology is used. Horizontal drivers are built on the panel. NTSC and PAL format are compatible. Horizontal scan can be from left to right or from right to left and Vertical scan can be from up to down or from down to up.

2. GENERAL SPECIFICATIONS

Item	Description	Unit
Display Size (Diagonal)	7.0 (17.8)	Inch (cm)
Display Type	Transmissive	
Active Area (HxV)	155.00 X 87.12	mm
Number of Dots (HxV)	854 X RGB X 480	dot
Dot Pitch (HxV)	0.0605 X 0.1815	mm
Color Arrangement	RGB Stripe	
Color Numbers	262K	
Outline Dimension (HxVxT) *	166.4 x 106.3 x 8.5	mm
Weight	215+/-5	g

* Exclude protrusions

3. INPUT/OUTPUT TERMINALS

3.1 TFT LCD Panel

Recommend Connector Type: OMRON XF2H-4015-1LW

Pin	Symbol	Description	Remark
1	VDD	Power Supply: +3.3V	
2	VDD	Power Supply: +3.3V	
3	VDD	Power Supply: +3.3V	
4	VDD	Power Supply: +3.3V	
5	NC	No Connection	
6	DE	Data Enable	
7	GND	GND	
8	VS	VSYNC	
9	GND	GND	
10	HS	HSYNC	
11	GND	GND	
12	B5	Digital Input Data Blue5	
13	B4	Digital Input Data Blue4	
14	B3	Digital Input Data Blue3	
15	GND	GND	
16	B2	Digital Input Data Blue2	
17	B1	Digital Input Data Blue1	
18	B0	Digital Input Data Blue0	
19	GND	GND	
20	G5	Digital Input Data Green5	
21	G4	Digital Input Data Green4	
22	G3	Digital Input Data Green3	
23	GND	GND	
24	G2	Digital Input Data Green2	
25	G1	Digital Input Data Green1	
26	G0	Digital Input Data Green0	
27	GND	GND	
28	R5	Digital Input Data Red5	
29	R4	Digital Input Data Red4	
30	R3	Digital Input Data Red3	
31	GND	GND	
32	R2	Digital Input Data Red2	
33	R1	Digital Input Data Red1	

34	R0	Digital Input Data Red0	
35	NC	No Connection	
36	CSV	Up/Down Inverse Control Signal	Note3-1
37	GND	GND	
38	NCLK	Input Clock	
39	GND	GND	
40	CSH	Right/Left Inverse Control Signal	Note3-2

Note 3-1: H: Normal scan,

L: Reverse scan



Note 3-2: H: Normal scan,

L: Reverse scan



3.2 Light Source

Light Source Type: CCFL Backlight

Recommend Connector Type: JST BHSR-02VS-01

3.2.1 CCFL 1

Pin	Symbol	Description	Remark
1	V _H	High Voltage for Backlight	Color: Pink
2	V _L	Low Voltage for Backlight	Color: White

3.2.2 CCFL2

Pin	Symbol	Description	Remark
1	V _H	High Voltage for Backlight	Color: Pink
2	V _L	Low Voltage for Backlight	Color: Black

4. ABSOLUTE MAXIMUM RATINGS

Item	Symbol	Min	MAX	Unit
Power Supply for Driver	VDD	-0.3	4.0	V
Back Light Lamp Current	I_L	--	10	mA
Operating Temperature	Topr	-30	+85	
Storage Temperature	Tstg	-30	+85	

5. ELECTRICAL CHARACTERISTICS

5.1 TFT LCD Module

VSS=0V, Ta=25

Item	Symbol	MIN	TYP	MAX	Unit	Remark
Power Supply for Driver	VDD	3.0	3.3	3.6	V	
Module Power Consumption	W_p	TBD	TBD	TBD	mW	Panel + System
B/L Lamp Current	I_L	3	5	8	mA_{rms}	
B/L Lamp Voltage	V_L	--	400	--	V_{rms}	$I_L=5mA$
B/L Frequency	F_L	45	50	55	kHz	$I_L=5mA$
Kick -off Voltage	V_s	--	--	470	V_{rms}	$I_L=5mA$
Backlight Power Consumption	W_{BL}	--	4.0	--	W	CCFL*2
Backlight Life Time	L_{BL}	10,000	15,000	--	hrs	Note 5-1

Note 5-1: Backlight luminance is not less than 50% of initial value at $I_L=5mA$.

5.2 TFT LCD Module Block Diagram

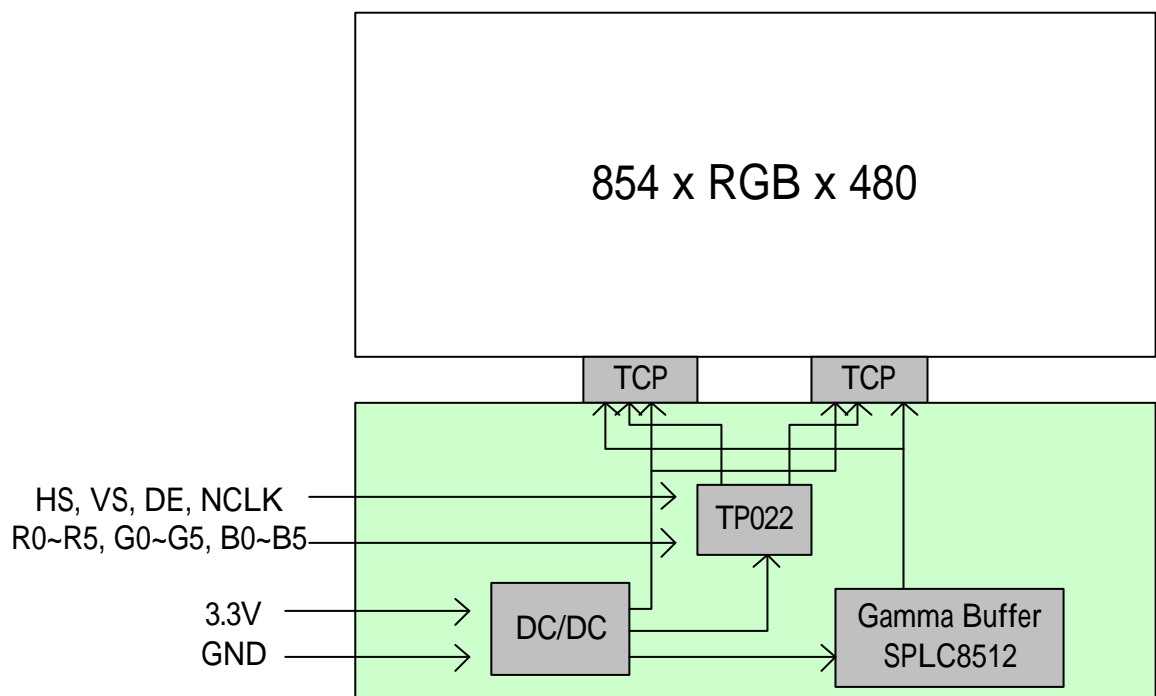

6. TIMING CHART

6.1 Timing Chart

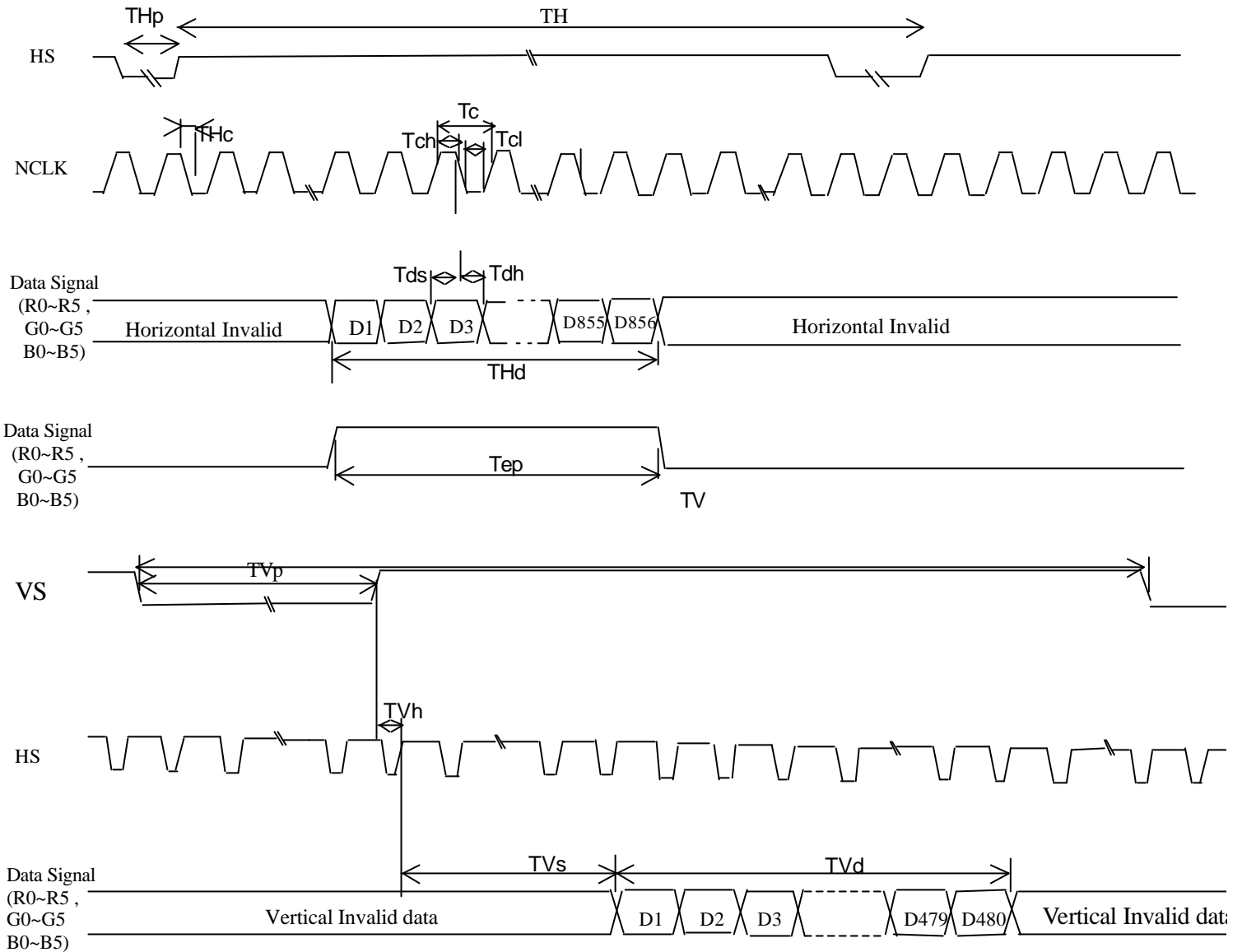

6.2 Timing Characteristics

Parameter		Symbol	MIN	TYP	MAX	Unit	Remarks
Clock(NCLK)	Frequency	1/Tc	--	33.2	36.2	MHz	Tc=t _{ncclk}
	High Time	Tch	5	--	--	ns	
	Low Time	Tcl	5	--	--	ns	
Data	Setup Time	Tds	3	--	--	ns	
	Hold Time	Tdh	10	--	--	ns	
Horizontal sync. Signal	Cycle	TH	30.0	31.8	--	us	
			1010	1056	1088	clock	
	Pulse Width	THp	2	115	177	clock	
Vertical sync. Signal	Cycle	TV	515	525	560	line	
	Pulse Width	TVp	1	4	6	line	
Horizontal display period		THd	856	856	856	clock	
Hsync-Clock phase difference		THc	10	--	Tc-10	ns	
Hsync-Vsync phase difference		TVh	0	--	TH-THp	ns	
Vertical display start position		TVs	23	23	23	line	
Vertical display period		TVd	480	480	480	line	
Enable signal	Setup time	Tes	5	--	Tc-10	ns	
	Pulse width	Tep	2	856	TH-10	clock	

7. OPTICAL CHARACTERISTICS

7.1 Optical Specification

Ta=25

Item	Symbol	Condition	MIN	TYP	MAX	Unit	Remarks	
Viewing Angles	11	CR = 10	55	65	--	Degree	Note 7-1	
	12		55	65	--			
	21		40	50	--			
	22		50	60	--			
	11	CR = 5	--	70	--			
	12		--	70	--			
	21		--	70	--			
	22		--	70	--			
Contrast Ratio	CR	=0°	350	450	--		Note 7-2	
Response Time	Rising		Tr	--	7	10	ms	Note 7-3
	Falling		Tf	--	18	25		
Luminance (I _L =5mA)	L			350	400	--	cd//m ²	Note 7-4
Chromaticity	White		x _w	0.28	0.31	0.34		Note 7-5
		y _w	0.30	0.33	0.36			

7.2 Basic Measure Conditions

- (1) Driving voltage
VDD= 3.3V
- (2) Ambient Temperature: Ta=25
- (3) Testing Point: Measure in the display center point and the test angle =0 °
- (4) Measurement System
 - a. Environmental illumination: = 1 Lux
 - b. Using the TOPCON BM-5A luminance meter
 - c. Using the Harison HIU 757 inverter

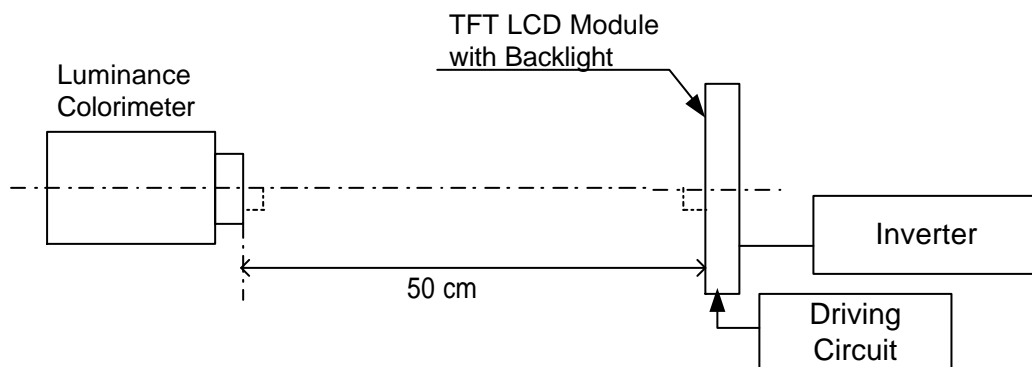

Note 7-1: Viewing angle diagrams:

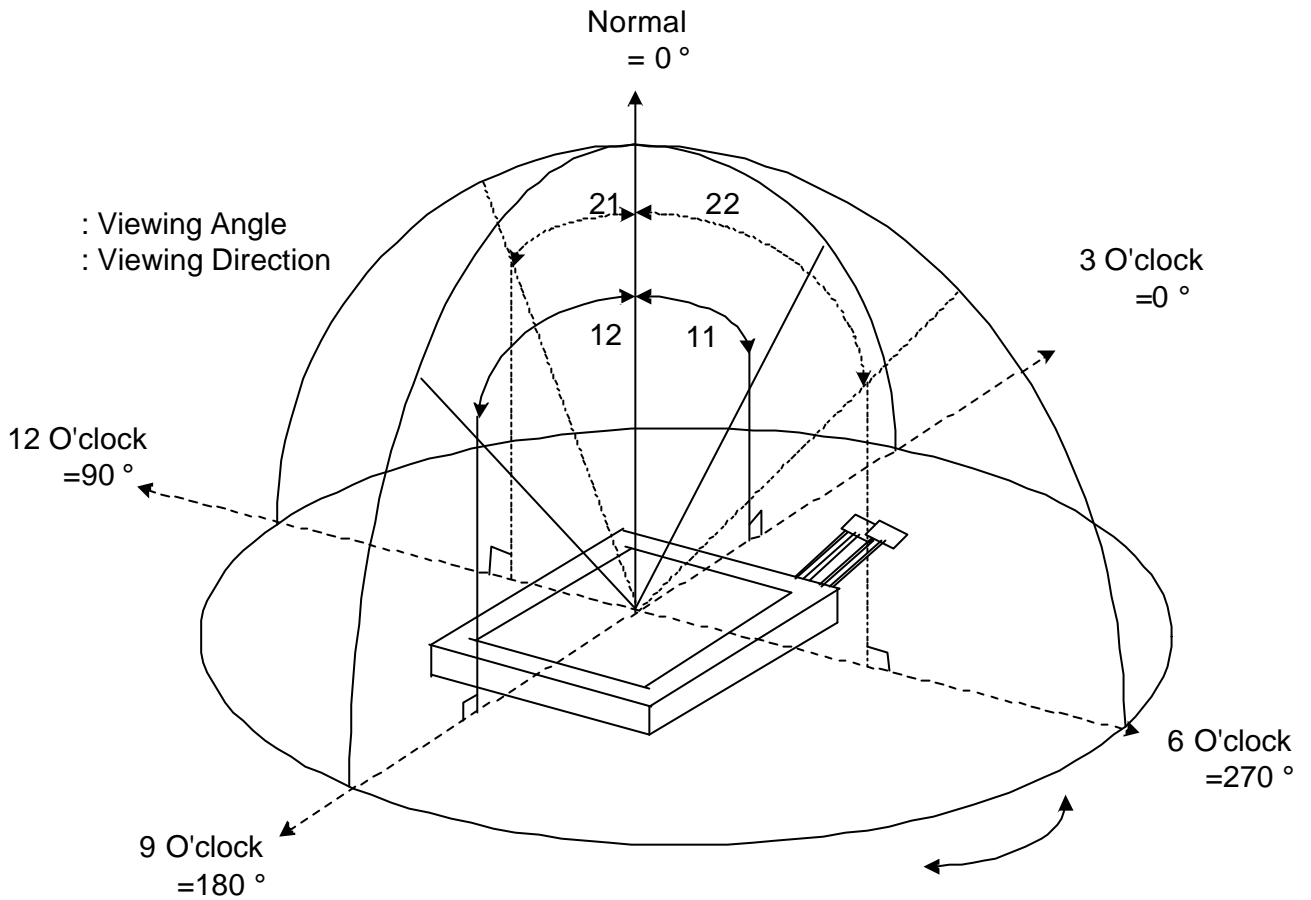

Note 7-2: Contrast ratio is measured in optimum common electrode voltage.

$$CR = \frac{\text{Luminance with white image}}{\text{Luminance with black image}}$$

Note 7-3: Definition of response time:

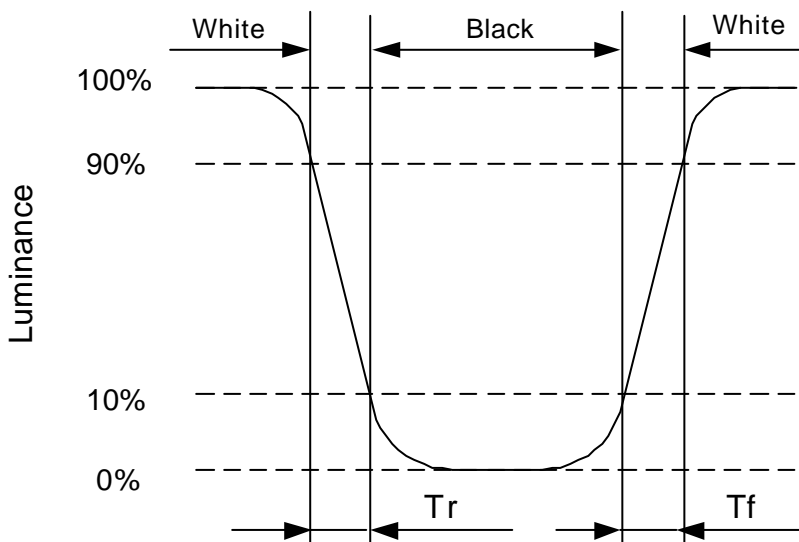

Note 7-4: Luminance:

L = White luminance at the center of the panel

Note 7-5: Chromaticity: The same test condition as Note 7-4.

8. REILIABILITY

No	Test Item	Condition
1	High Temperature Operation	Tp=+85 , 240hrs
2	High Temperature & High Humidity Operation	Ta=+40 , 95% RH, 240hrs
3	Low Temperature Operation	Ta=-30 , 240hrs
4	High Temperature Storage (non-operation)	Ta=+85 , 240hrs
5	Low Temperature Storage (non-operation)	Ta=-30 , 240hrs
6	High Temperature & High Humidity Storage	Ta=+60 , 90% RH, 240hrs
7	Thermal Shock (non-operation)	Test between -30 (duration 30 min.) and 85 (duration 30 min.), 50 cycles
8	Resistance to Static Electricity Discharge (non-operation)	C=200pF, R=00; Discharge: ±150V 3 times / Terminal
9	Surface Discharge (non-operation)	C=150pF, R=3300; Discharge: Air: ±15kV; Contact: ±15kV 5 times / Point; 5 Points / Panel
10	Vibration (non-operation)	Frequency range: 8~33.3Hz Amplitude: 1.3mm Sweep: 33.3~400Hz Acceleration: 3G Cycle: 15 Min X/Z 2 hrs for etch directions, 4 hrs for Y direction
11	Shock (non-operation)	Acceleration: 100G; Period: 6ms Directions: ±X, ±Y, ±Z; Cycles: Twice

Tp: Panel Temperature

Ta: Ambient Temperature

9. HANDLING CAUTIONS

9.1 ESD (Electrical Static Discharge) Strategy

ESD will cause serious damage of the panel, ESD strategy is very important in handling. Following items are the recommended ESD strategy

- (1) In handling LCD panel, please wear non-charged material gloves. Connect the wrist conduction ring to the earth and the conducting shoes to the earth are necessary.
- (2) The machine and working table for the panel should have ESD protection strategy.
- (3) In handling the panel, using ionized air to decrease the charge in the environment is necessary.
- (4) In the process of assembly the module, shield case should connect to the ground.

9.2 Environment

- (1) Working environment of the panel should be in the clean room.
- (2) The front polarizer is easy to be damaged. Handle it carefully and do not scratch it by sharp material.
- (3) Panel has polarizer protective film in the surface. Please remove the protection film of polarizer slowly with ionized air to prevent the electrostatic discharge.

9.3 Others

- (1) Turn off the power supply before connecting and disconnecting signal input cable.
- (2) The connection area of FPC and panel is very weak, do not handle panel only by FPC or bend FPC.
- (3) Water drop on the surface or condensation as panel power on will corrode panel electrode.
- (4) As the packing bag open, watch out the environment of the panel storage. High temperature and high humidity environment is prohibited.
- (5) When the TFT LCD module is broken, please watch out whether liquid crystal leaks out or not. If your hand touches liquid crystal, wash your hand cleanly by water and soap as soon as possible.

10. MECHANICAL DRAWING

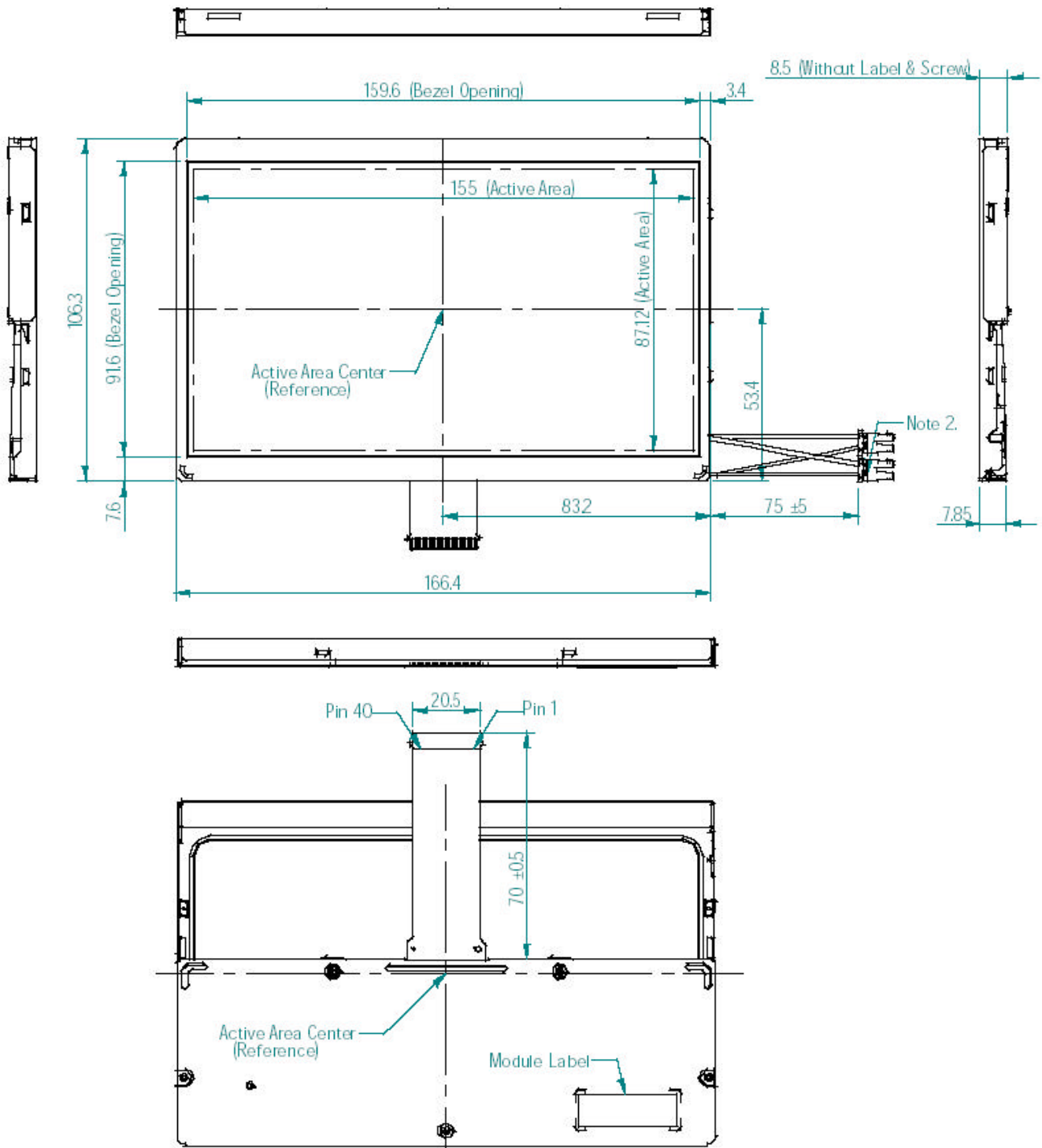

Note :

1. The tolerance of size which isn't being indicated is ± 0.4 ◊
2. CN Type : JST BHSR-02VS-01 ◊

11. PACKING DRAWING

